

EQUIPMENT REVIEW

P. SIMPSON G3GGK and B. ARMSTRONG G3EDD

THE HEATHKIT MONITOR SCOPE SB-610E

ONE of the ancillary equipments available in the Heathkit SB range is the monitor oscilloscope SB-610E. Manufactured by the Heath Company USA, it is marketed in the UK by Daystrom Ltd., Gloucester. The price is now £41 14s. as a kit or £51 14s. assembled.

The unit is designed to monitor r.f. envelopes from a.m., s.s.b. or c.w. transmitters, i.f. waveforms in receivers for a variety of intermediate frequencies, or RTTY tones.

General Description

The circuit is simple and full use is made of multi-electrode valves including the 6BN8 double diode triode, the 6C10 triple triode and the 6J11 double tetrode. The latter valve generates the two audio frequencies, 1500 and 1950 Hz. The kit allows for the vertical amplifier to be wired in slightly different ways to cover 1 to 150 kHz, 455-2475 kHz or 3 to 6 MHz. The horizontal deflection amplifier (1/3 6C10) may be switched to an external socket, internally detected r.f. or the internal sweep generator. A switchable clamping circuit is included so that when in operation but with no r.f. input the spot is deflected off the screen to avoid screen burn.

The front panel controls consist of FOCUS, INTENSITY, VERTICAL SHIFT, HORIZONTAL SHIFT, VERTICAL GAIN, HORI-

ZONTAL GAIN, SWEEP SOURCE (internal, external a.f., or internally demodulated r.f.), TONE GENERATOR (off, 1500 Hz or 1500 plus 1950 Hz), SWEEP FREQUENCY, CLAMP IN/OUT and the ON/OFF switch. A 2 in. x 2 in. graticule is provided over the face of the 3 in. diameter 3RP1 cathode ray tube. The rear panel contains two phono sockets for exciter in and out; two UHF series SO239 sockets for aerial in and out; three phono sockets for tone output, vertical input, and horizontal input; and a transmitter attenuator to adjust the amount of r.f. pick up from the aerial in/out sockets.

Aluminium metalwork is used throughout and the case is painted in two-tone green to match the rest of the SB series.

The internal power supply provides -1430 volts from a selenium rectifier full wave voltage doubler. Silicon diodes in a voltage doubler circuit are used for +600V d.c. and the same circuit also provides +290V d.c.

Transmitter Monitoring

The transmitter output is fed to a dummy load or aerial via co-axial aerial terminals; the c.r.t. then shows the r.f. envelope. For p.e.p. or linearity checks the two tone generator is fed into the transmitter mic. input. An interest-

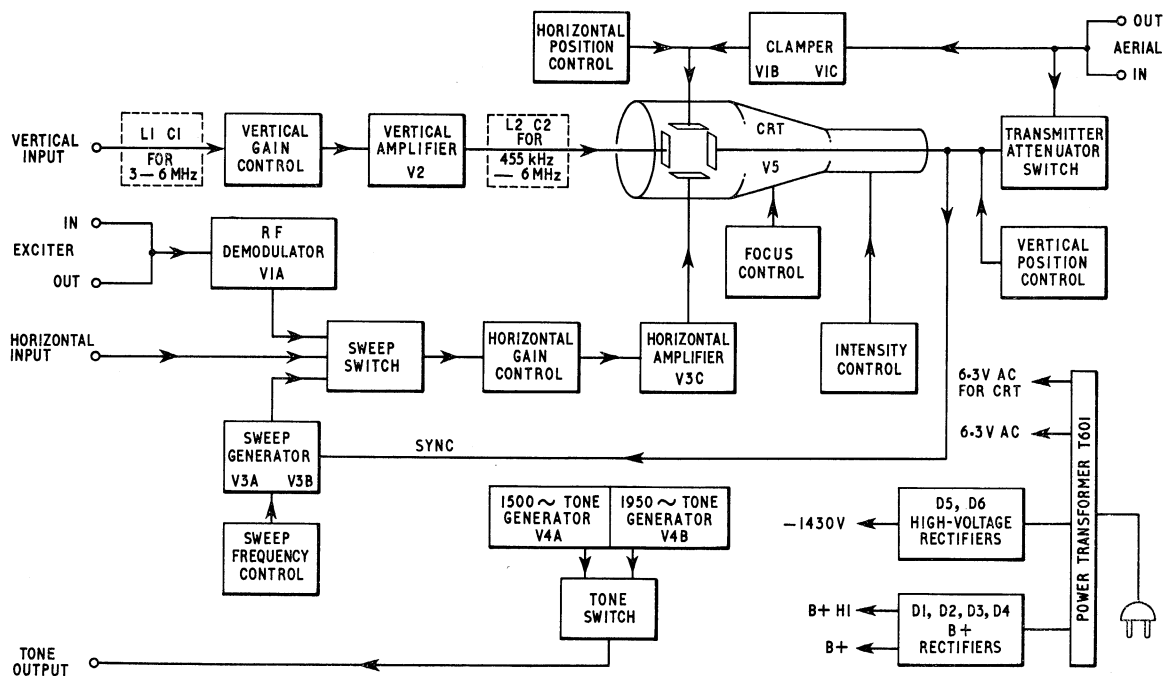

A block diagram of the Heathkit monitor scope SB-610E

ing application is that the linearity of a linear amplifier can be checked by connecting the output of the exciter via the monitor. R.f. from the exciter is detected and applied as the horizontal time base and the linear r.f. is used for the vertical deflection. The shape of the resulting trapezoid is an indication of the linearity.

Receiver Monitoring

The receiver output is normally taken from the grid of the last i.f. stage and is applied to the vertical input socket of the monitor. Care has to be taken in the interpretation of the envelopes displayed since the receiver a.g.c. and selectivity can considerably modify the envelope of the transmitted signal. The manufacturers have since pointed out that it has been found preferable in some cases to connect via the anode of the last i.f. amplifier. This is to take advantage of the gain to obtain maximum display of small signals.

TTY Monitoring

By feeding mark and space outputs from the terminal equipment into horizontal and vertical inputs respectively a cross can be displayed. Once the amplitudes have been properly set up on a known good terminal output, the patterns produced by a received signal can be interpreted.

Construction

The particular SB-610 under review was purchased as a kit by a commercial organization and made up by a professional wirer in her spare time. About 15 hours were spent in the construction with no snags or "odds" encountered. The unit did not work on switch-on but this was a human error and not the fault of the Heathkit Manual which, if properly followed, appears foolproof.

Tests

Sweep frequency: 11 Hz to 128 Hz.

Horizontal amplifier: 3dB at < 20 Hz and 25 kHz

Maximum sensitivity 830 mV per in. deflection.

Audio oscillators:

Maximum 50 mV 1526 Hz 8.5 per cent distortion

Maximum 50 mV 1970 Hz 12.5 per cent distortion

Vertical amplifier

Maximum sensitivity 133mV per in. deflection at 14 MHz

R.f. power sensitivity: 40 watts p.e.p. for 1 in. deflection.

In Use

The monitor was easy to use and proved to be a most useful piece of test gear. When first using the monitor it tends to be treated as a "gimmick" but it soon becomes an essential. After a short period of use the e.h.t. rectifiers failed and were replaced with similar types which gave no further trouble.

The Assembly Manual

This 55 page book is an excellent document which is easy to follow and contains a wealth of information apart from that concerned with assembly. The only odd thing is that there is no direct cross reference between part numbers in the parts list and component references in the excellent circuit diagram.

Manufacturer's Specification

Vertical Amplifier

Input Resistance 100 k ohms.

Sensitivity

	Optional frequency inputs	Nominal input voltage (r.m.s.) per in. of vertical deflection
Untuned	10 Hz to 400 Hz	2.0V
	400 Hz to 10,000 Hz (RTTY)	1.0V
	10 kHz to 455 kHz	500mV
	455 kHz	70 mV
Tuned	1600 to 1680 kHz	200 mV
	2075 kHz	200 mV
	2215 kHz	200 mV
	2475 kHz	200 mV
	3000 kHz	400 mV
	3055 kHz	400 mV
	3395 kHz	500 mV
	5000 to 6000 kHz	600 mV

Horizontal Amplifier

Frequency Response

± 3dB from 3 Hz to 15 kHz

Sensitivity

800 mV per in. deflection.

Input resistance

1 megohm

Sweep Generator

Recurrent type

Sawtooth produced by internal sweep generator

Frequency

15 to 200 Hz (variable)
(amended to 10 to 125 Hz)

Tone oscillators

Frequencies

Approximately 1500 Hz and 1950 Hz

Output voltage

50 mV (nominal)

General

Frequency coverage

160m through to 6m (50-75 ohm coaxial input)

Signal Power Limits (at rear co-axial connector)

15 watts to 1 kW

Valve and diode complement

- 1—3RP1 CRT, medium persistence, green trace
- 1—6BN8 Clamper, low level r.f. detector
- 1—6C10 Sweep Generator, horizontal amplifier
- 1—6J11 Twin phase-shift tone generator
- 1—6EW6 Vertical amplifier
- 1—Germanium diode, sync. rectifier
- 4—Silicon diodes, B + rectifiers
- 2—Selenium diodes, high voltage rectifiers

Front Panel Controls

- Sweep
- Sweep frequency—pull for clamp
- Tone at generator
- Horizontal gain
- Horizontal position
- Vertical gain
- Vertical position
- Focus
- Intensity—a.c. off

Rear Panel Control

- Transmitter attenuator, Attenuates to 24dB at approximately 8dB per step.

Power Supply

Power requirements

Transformer operated, fused at 1/2A 115 or 230V* a.c. 50.60 Hz 35 watts

Dimensions

6 in. high × 10 in. wide × 1½ in. deep (including knobs).

Net Weight

9 lb. 10 oz.

* Export Model.

Conclusions

For the s.s.b. operator particularly, a visual monitor should be an essential piece of station equipment. Judging from many stations heard on the air, few have means of judging the quality of the signal they are transmitting. The SB610 provides the means and is certainly not expensive for what it does.

Heathkit SB-610 Monitor Scope Modifications

Ian A. Webb K6SDE
432 Rosario Dr.
Santa Barbara, Calif. 93105

Proper optimum operation of single side-band transmitters is most easily achieved by oscilloscope monitoring. As a result, the Heathkit SB-610 Monitor Scope* is appearing in more and more amateur shacks as a vital piece of equipment. As originally designed, this equipment is a versatile piece of gear. There are a couple of modifications, however, that make this an even more versatile instrument.

I will describe two modifications that I have made to my SB-610. Neither modification requires new front panel holes or mechanical changes to affect the resale value of the SB-610. Most owners of the SB-610 should consider at least the first modification. Those who have yet to acquire an SB-610 may wish to incorporate the modifications when they construct the kit.

Transmitter attenuation switch

This modification moves the transmitter attenuation switch from its present position in the center of the rear apron of the SB-610 to the front panel. The control becomes concentric with the present vertical gain control. With the transmitter attenuation control on the front panel, it is no longer necessary to reach behind the SB-610 to change the transmitting pattern height when changing power levels or making band changes. This is especially useful when one changes bands frequently or where a linear amplifier is often switched on or off.

Parts required:

- Concentric potentiometer element (outer unit) and shaft assembly, 100 K linear (IRC-CTS CF 13 or equivalent, see text)
- Potentiometer mounting bracket (See Fig. 1)
- Non-conducting shaft ($\frac{3}{16}$ inch diameter by 10 inches approx.)

- $\frac{3}{8}$ inch "butch plug"
- Lever knob*
- Control knob split bushing*

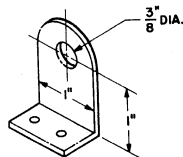

Mounting Bracket

In this modification, the present 100 K linear vertical gain control, which is in the lower center of the front panel, is replaced with a 100 K linear concentric potentiometer. A Heathkit lever knob, matching the present SB-610 knobs, is put on this new potentiometer. This leaves a hole through the center of the vertical gain control in which to run

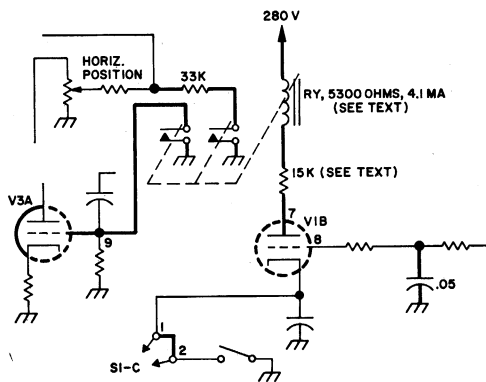

Modification Schematic

the insulated shaft which controls the transmitter attenuation switch which is remounted on a new bracket facing forward.

The choice of concentric potentiometer is not critical and by browsing in your local parts house stock of replacement type controls you should find a "make your own pot" selection enabling you to assemble the "outside" portion of a dual potentiometer. (I used an IRC-CTS CF-13 unit with a panel bushing about $\frac{3}{8}$ inch long and a shaft about

*"Heathkit SB-610 Monitor Scope," 73 Magazine, (December 1966), 54.

*Order Heathkit numbers 455-11 Split Bushing \$1.0 and 462-195 Lever knob \$.50 (postpaid) from: Heath Company, Benton Harbor, Michigan 49023.

$\frac{1}{8}$ inch long which I cut to exactly fit the Heathkit lever knob.)

Remove all three wires to the lugs of the old vertical gain control (AJ in the SB-610 manual) and remove the old control and knobs keeping the wires in order so they may be soldered to the new control. Before mounting the new pot, be sure that the knob shaft will extend just far enough to allow you to mount the new lever knob on it. Do any cutting of the shaft before mounting the potentiometer to prevent damage to the front panel of the SB-610. Mount the new control and resolder the wires to the corresponding lugs of the new control.

Fabricate a bracket as shown in Fig. 1 and refer to the photos to see mounting details. (If you are lucky as I was, your junk box will yield a suitable bracket.) Unsolder the wire from the coaxial connector to the lug 4 of switch BD, the transmitter attenuation switch, and unsolder the capacitor which runs from terminal strip G, lug 5 to terminal 5 of switch BD. You can now remove the switch from the back apron. If you wish, fill the empty hole in the back apron with a "butch plug."

Mount the new mounting bracket in line with the old hole in which the switch was mounted. Allow enough room for the switch to be remounted between the new bracket and the back apron. Mount the switch and reattach the wire from the coaxial connector to terminal 4 and the capacitor to terminal 5 of the remounted switch. Orient the switch so this can be accomplished with the least difficulty. Be certain that no components stick up far enough to interfere with the case when it is replaced over the Monitor Scope.

Attach the shaft coupler to the switch shaft and insert the $\frac{3}{16}$ inch non-conducting shaft extension from the front panel into the hole through the vertical gain control running it back to the shaft coupler. Carefully move any parts that interfere with the shaft. The large .25 mfd capacitor near the shaft coupler between the tube socket (V3) and the terminal strip G may need to be relocated to provide sufficient clearance. A metallic shaft extension is *not recommended* due to the possibility of accidental contact with parts on the chassis.

When the shaft has been properly mated, make a small shim from a piece of scrap or tin can to reduce the $\frac{1}{4}$ inch coupler on the switch to accept the $\frac{3}{16}$ inch shaft extension. With the shaft in place measure

$\frac{1}{2}$ inch beyond the lever knob mounted on the vertical gain control and remove and cut the shaft at this point. Mount the shaft firmly, tightening the coupler. Use the new split bushing inside the original knob removed from the vertical gain control to firmly fasten the knob onto the shaft extension flush with the lever knob.

The SB-610 will now operate exactly as it did originally. It is now possible to select the vertical gain when monitoring a received signal using the lever knob and to change the transmitter attenuation using the large original knob. It is no longer necessary to reach behind the SB-610 each time the linear is turned on or off or each time you need attenuation changes when switching bands.

Clamp Modification

This modification should appeal to those people, myself included, who believe that the main virtue of the SB-610 is the monitoring of one's transmitted envelope using the internal sweep. If you use the internal

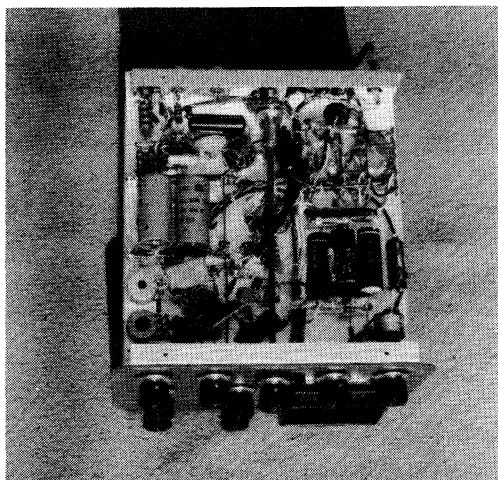

Top View

sweep *without also monitoring received signals* during standby periods, the trace of the SB-610 will remain a static baseline of high intensity since the clamp circuit is inoperative in this mode. This can cause a burned scope face if the intensity is high enough for good monitoring of peaks in a brightly illuminated room. I decided that I would like to remove the trace from the scope face automatically when the transmitter is turned to standby. This could be done using the relays that switch the rig from transmit to receive, but since my rig is a transceiver

that I also use when mobile, this would involve additional connections to attach and remove each time I switched from base station to mobile operation. My modification accomplishes the clamping of the trace with no additional connections to the transmitter or receiver.

Parts required:

Capacitor, .05 mfd, 50 volts

Resistors: 33K, ½ watt and resistor in series with relay coil (see text)

Sensitive plate relay, DPST, N.O., (Lafayette Radio 99H6093, DPDT, 5300 ohm, 4.1 ma., 4 oz., shipping weight, \$2.95, Lafayette Radio, 111 Jericho Turnpike, Syosset, L.I., N.Y. 11791) See text for details.

The relay I used, was from my junk box. Lacking a suitable relay, the one listed in the list above is suggested. It may require ingenuity to mount some relays, but a small bit of epoxy will do wonders if properly applied.

Fig. 4 shows the circuit modifications to be made. The dark portions of the circuit are additional components or modifications. The clamp tube, V1B, is turned into a relay amplifier. Relay contacts are used to pull the trace off the screen by shorting the horizontal position control through a 33 K resistor. A second set of contacts grounds the grid of V3A to stop the sweep. If the sweep is not disabled, the left portion of the trace will still be on the screen. Pins 1 and 2 of the front panel sweep control are jumpered so that the "pull for clamp" control will work in the internal sweep position of the sweep control as well as in the other sweep positions. When this modification is made, the SB-610 will operate as originally designed in the RTTY and *rf* Trap positions of the sweep switch. The clamp will also work in the internal (Int.) position of the sweep control when the "pull for clamp" control is pulled out. The clamp switch may be pushed in so that received signals may also be monitored as originally designed.

The .2 microfarad capacitor on terminal strip H adjacent to tube socket V1 is changed to .05 microfarads to allow 1 to 2 seconds before the trace leaves the screen. This capacitor need not be changed, but the time for the trace to leave the screen will be in excess of ten seconds if it is not changed. Remove the capacitor from strip H and replace it with the .05 mfd capacitor if you desire this change.

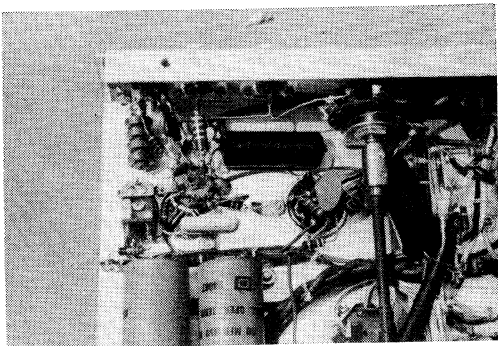

Bottom View

The left hand lug of terminal strip U, near the chassis edge was originally unused. Remove the blue wire at pin 7 of V1 and solder it to this unused lug of terminal strip U. On the back of the front panel, solder a jumper wire between lugs 1 and 2 of the sweep switch.

Mount the plate relay in the space between the tube socket V1, terminal strip U and the edge of the chassis. If your relay can be mounted with screws as could my junk box relay, that is fine; otherwise you may have to use some ingenuity and perhaps some epoxy to mount the relay.

From one set of relay contacts (closed when the relay is operated) run a wire to a convenient ground point such as the mounting lug of terminal strip U. From the other contact of the set, connect the 33 K resistor to the blue wire which you soldered to the previously unused lug of terminal strip U near the outside of the chassis.

From the second set of contacts (also closed when the relay is operated) run a wire to ground. From the other contact of this set, run a wire to pin 9 of tube socket V3A which is the tube socket near the *sm* extension. This set of contacts will now ground the grid of tube V3A when the relay is closed and stop the sweep.

Run a wire from one end of the relay coil to the 280 volt bus. I ran the wire to the junction of the 40 mfd capacitor; 15 K, 1 W resistor; 1 K, 1 W resistor; and 20 mfd capacitor. This is near the center of the chassis on capacitor K, pin 3.

Temporarily, attach the remaining end of the relay coil to pin 7 of V1 through a resistor. (This resistor should be nominally 15 K ohms for the relay in the parts list.) The resistor should be selected so that the relay used just pulls in reliably when the

clamp switch is pulled out, the SB-610 turned on, and no *rf* signal is applied. In any event, the plate dissipation of the 6BN8 relay amplifier should not exceed the maximum rating of 1.7 watts. The total resistance of the relay coil plus series resistor should be at least 10 K. (If you use a junk box relay, measure the voltage from cathode to plate, and the current through the tube when the relay is pulled in. The product of the voltage and current—in amperes—should not exceed 1.7.)

This completes the wiring of the modification. Check the wiring against the schematic in Fig. 4. Carefully plug the SB-610 in with it still out of the case and let it warm up. Check to see if the relay operates when the "pull to clamp" switch is pulled out and the sweep switch is in any position. If the relay does not operate, first recheck the wiring to make sure it is correct. If the wiring is correct and the relay will still not pull-in, reduce the value of the resistor from the relay coil to pin 7 of V1 until the relay reliably pulls in. This will assure that minimum plate dissipation occurs in tube V1. When this value is found, solder in the resistor permanently.

When the "pull to clamp" switch is pushed in, the relay should drop out. The trace will then appear on the face of the SB-610 and it should operate normally.

Set the sweep switch to Int. and apply a small amount of transmitter *rf* to the connector at the rear of the SB-610 while the "pull to clamp" switch is out. The relay should release and the trace should appear to allow normal transmitted signal monitoring. If the trace does not appear and the relay drop out, increase the *rf* signal. When the *rf* is removed by turning off the transmitter, the trace should disappear after 1 to 2 seconds. If the trace has not moved completely off the scope face, it may be necessary to decrease the value of the 33 K resistor. If the sweep still continues when the trace is off screen, the grid of tube V3A (pin 9) is not being shorted to ground through the relay.

I have operated my SB-610 24 hours a day for days at a time and experienced no difficulties. You must now remember to turn off the power switch after operating, for you no longer see the green trace on the screen to remind you that the SB-610 is on.

... K6SDE

Using the Heathkit SB610 scope with the Drake line

by R. S. PACE, G3SOI*

THIS scope is an excellent unit for monitoring a transmitted signal, but many operators also use it to monitor the received signal. For this purpose Heathkit provide three input circuits for use with receivers having final i.f. frequencies falling within the bands 1-150kHz, 455-2,475kHz and 3,000-6,000kHz. The input sensitivity of the SB610 varies widely over these ranges.

The Heathkit circuit for 50kHz is shown, as this is the frequency used by Drake. When the author built this scope the main receiver in use was a Drake 2B, and the plate

V5 (the 6BA6 final i.f. amplifier) was connected to the vertical input socket of the scope via a capacitor of 56pF; this large value gave a maximum deflection of about 1in and caused no de-tuning of the i.f. stage.

When the 2B was changed for a Drake R4B, problems arose, as Drake advised that a coupling capacitor of not more than 20pF should be used, and they also suggested that the avc be switched off when receiver monitoring was required as the deflection with avc in use would be too small. In practice this was unsatisfactory and it was decided to increase the input sensitivity of the SB610.

Heathkit do not make a coil for 50kHz as they do for the other two frequency ranges, so an i.f. transformer type T10, used in the last i.f. stage of the R4B, was obtained and the primary winding connected as shown. On the R4B there is provision for a spare phone socket on the chassis rear, and a screened connection was made from this via a 22pF silver mica capacitor to the plate of V5 (12BA6), the last i.f. amplifier. Receiver and scope were switched on and

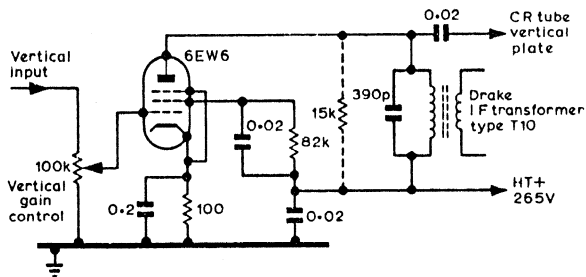

The 15kΩ 1W resistor in the original circuit is removed (shown by dotted lines) and the primary winding of the T10, tuned by 390pF capacitor, is substituted. The secondary winding is left open circuit

the core of the T10 peaked for maximum deflection using a weak signal with the receiver avc off. No de-tuning occurred and the deflection obtained was 1½in on full vertical gain using avc.

The R4B has now been changed for an R4C and by using a 12.5pF capacitor from the plate of V5 (6BA6) this time, a slightly greater deflection was obtained. There is no provision for a spare socket on the R4C but a phone socket can be fitted through the large hole next to the earthing post, strangely called line amp, anchoring it by a bolt through the small hole above and by a solder tag to the nearest bolt on the multi-phone socket strip on the left below. It is not necessary to drill any holes.

Again, drilling is not necessary when fitting the Drake T10 can assembly to the scope, as the mounting clip on the can, although different from that used by Heathkit, fits perfectly well in the cut-out on the chassis.

The author has never used a Drake R4 or R4A, but as the voltage swing on the last i.f. amplifier in these receivers is similar, the same result should be obtained.

*22 The Drive, Shotley Bridge, Consett, Co Durham

tube and the power transformer. In the new model (SB-610) Heath has switched to an aluminum chassis and has eliminated the baffle plate. As a result the power transformer is not isolated from the CRT by effective shielding. The mu-metal CRT cover does not eliminate all of the ac radiated by the transformer.

I found that ripple reduction can be greatly improved by using better CRT shields. This was proved when a second shield was purchased and placed over the original one. This extra-shielding method has been used by transformer manufacturers to provide hum isolation in their high-grade broadcast transformers for audio applications, so the technique is sound. — *Maurice P. Johnson, W3TRR*

REDUCING BASELINE RIPPLE IN THE SB-610 MONITOR SCOPE

I noted with interest the "Recent Equipment" review of the Heath SB-610 in the July, 1972 issue of *QST*, since I have the older HO-10 and the SB-610. As is pointed out, there is little electrical difference in the two versions of the Monitorscope. However, in the SB-610 there is greater baseline ripple than in the HO-10. A check of the power supply output was made. Insufficient filtering was not the reason for this ripple.

Further checking revealed that the HO-10 used a steel chassis with a baffle plate between the CR